

## Mass spectrometry

# TSQ Altis Plus triple quadrupole mass spectrometer

## Ultimate quantitative performance made possible

### Benefits

- Ultimate quantitative performance is achieved through enhanced Thermo Scientific™ Active Ion Management (AIM+) technology
- QR5 Plus segmented quadrupoles with hyperbolic surfaces deliver attogram sensitivity consistently and reproducibly
- Industry-leading selected-reaction monitoring (SRM) speeds enable quantitation of more compounds in less time
- Provides robustness, reliability, and consistency that are unprecedented in a high-end triple quadrupole mass spectrometer
- Gives industry-leading polarity switching times that include signal stabilization
- Provides automated compound optimization and intuitive instrument interface
- Access to the comprehensive Thermo Scientific™ mzCloud™ compound database

The Thermo Scientific™ TSQ Altis™ Plus mass spectrometer redefines ultimate performance and flexibility to address demanding quantitation workflows with ease. With superior acquisition speeds, enhanced sensitivity, and stability, the TSQ Altis Plus mass spectrometer delivers unprecedented accuracy and precision for low-level compounds in complex matrices. Advanced control software, database integration, and templates streamline rigorous method development. Combined with powerful Thermo Scientific™ chromatographic systems, optional differential ion mobility, novel ionization sources, and leading fit-for-purpose data-processing software, a TSQ Altis Plus solution provides the highest performance for your most challenging quantitative applications.



### Hardware features

#### Active Ion Management

AIM+ technology maximizes ion transmission, from inception to detection, with novel hardware designs to precisely manage electrical fields and remove sources of noise to achieve unprecedented levels of quantitative performance.

#### Thermo Scientific™ OptaMax™ NG API source

- Automatic connection of all gases and voltages on installation simplifies operation and improves reliability
- Automatic source recognition simplifies use and data logging
- Sweep gas reduces chemical noise
- Enhanced exhaust port efficiently removes solvent vapor, improving uptime and reducing chemical noise
- Flexible X, Y, and Z positioning for all ionization probes maximizes performance
- Optimal 60-degree spray angle

## TSQ Altis Plus ion flight path

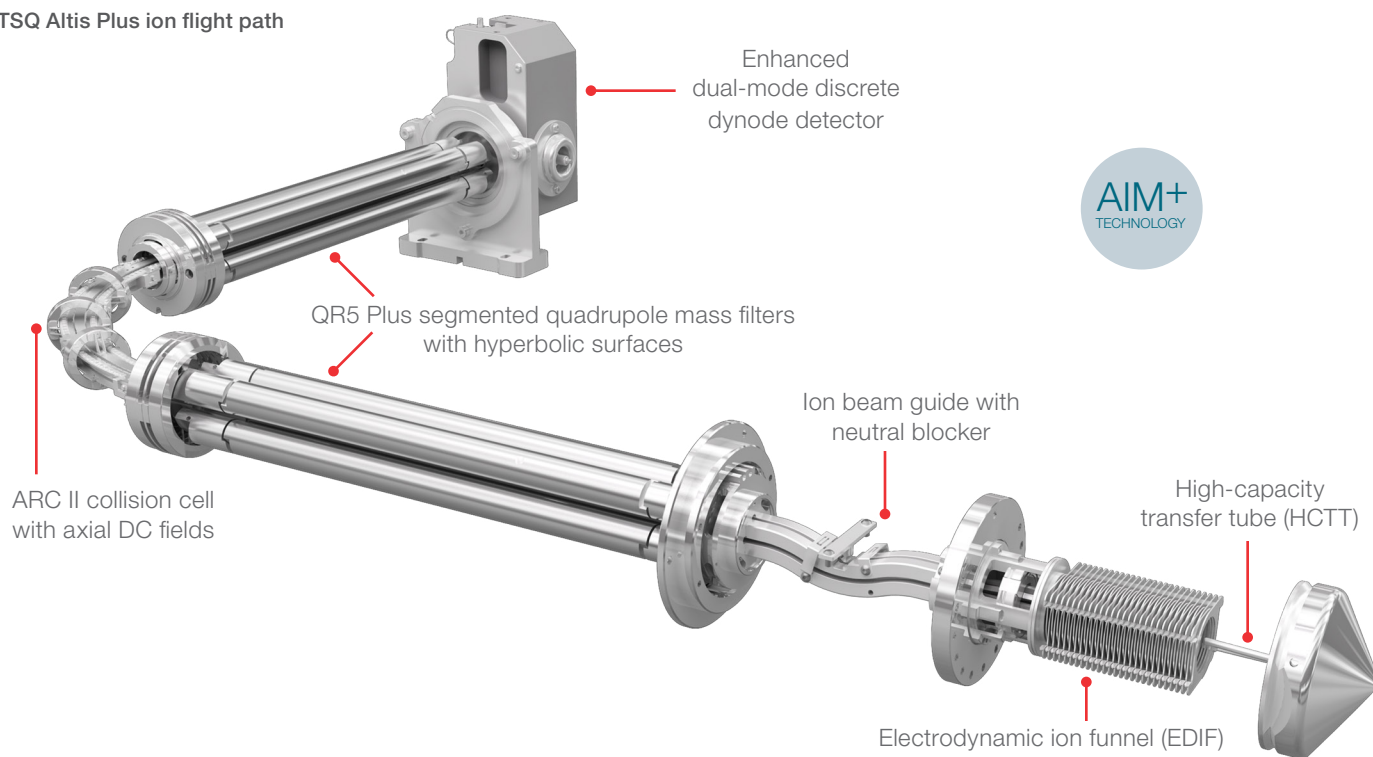

- Integrated APCI functionality with interchangeable HESI and APCI ionization probes
- APPI compatibility
- Dedicated mass calibration probe

### High-capacity transfer tube

The optimized high-capacity transfer tube (HCTT) transfers more ions into the vacuum system for improved sensitivity while maintaining robustness and ease of use.

### Ion optics

#### *Electrodynamic ion funnel RF lens*

The electrodynamic ion funnel (EDIF) efficiently captures ions as they leave the transfer tube. Its broad transmission curve reduces ion losses, increasing sensitivity. By design, the EDIF gently moves ions from atmosphere to vacuum, reducing in-source fragmentation.

#### *Ion beam guide and neutral blocker*

The ion beam guide, with its neutral blocker, stops neutrals and high-velocity clusters, keeping the ion path cleaner, reducing noise and increasing sensitivity and robustness.

#### *QR5 Plus segmented quadrupole mass filters with hyperbolic surfaces (Q1 and Q3)*

Segmented hyperbolic-surface quadrupole mass filters with 5.25 mm field radius deliver industry-leading ion transmission across the mass range at resolutions up to 0.2 Da FWHM with improved mass stability for the ultimate in sensitivity at all masses and resolutions.

### *Active Reaction Collision cell II (ARC II)*

The 90-degree, high-pressure argon-filled collision cell produces efficient fragmentation for high sensitivity, while guiding ions away from neutral reaction products to reduce noise. The new design improves stability and transmission of low-mass product ions as well as product ions generated from large  $m/z$  differences between precursor and product ions, critical for key applications. The axial DC field speeds ion transits through the collision cell yielding up to 600 SRMs/sec with zero cross-talk, providing excellent sensitivity and speed.

### Detector

- Discrete-dynode detector with increased surface area greatly extends the detector lifetime
- Dual-mode function increases sensitivity by operating in pulse-counting mode when ion flux is low and analog mode when ion flux is high
- Greater than six orders of dynamic range provide high-confidence quantitation

### Vacuum system

- Four-stage differentially pumped vacuum manifold
- Advanced triple-inlet turbomolecular pump integrated with the vacuum manifold
- Single-stage, oil-sealed Rotary Vane vacuum-pump configuration
- Environmentally friendly dry-pump option available

## Integrated syringe pump

- Fully integrated into data control system that allows automated infusion, with plug-and-play support
- The data system is also capable of switching on and off the syringe pump in time segments

## Integrated optional divert valve

- The divert valve is under fully automated data control system
- Automated control of the divert valve enables switching of the solvent front, gradient end point, or any portion of the HPLC run to waste

## Optional ion sources

- Thermo Scientific™ EASY-Spray™ NG ion source is designed for maximum nanospray performance with no need for adjustments
- Thermo Scientific™ Nanospray Flex™ NG ion source is designed for ultimate nanospray performance with complete flexibility of column selection
- Thermo Scientific™ VeriSpray™ PaperSpray™ ion source enables seamless integration of paper spray technology for direct MS-based ionization
- Thermo Scientific™ OptaMax™ Duet NG API ion source enables HESI and APCI functionality without manual changes in the hardware configuration
- Thermo Scientific™ FAIMS Pro Duo interface improves signal-to-noise ratio by reducing isobaric interferences

## Software features

### Data system

- High-performance PC with Intel® microprocessor
- High-resolution LCD color monitor
- Microsoft® Windows® 10 operating system (64-bit)

### Standard MS software

- Thermo Scientific™ Xcalibur™ processing and instrument control software
- Thermo Scientific™ FreeStyle™ application for data processing
- Tune editor for system calibration, diagnostics, and manual data acquisition
- Fully automated loop injection or infusion-based compound optimization directly incorporated into the instrument method.

- Method editor with comprehensive application-specific template library and intuitive user interface to facilitate method development
- Thermo Scientific™ mzCloud™ database access allowing importation of compound name, SRM transitions, and collision energies
- Dwell time weighting factor for optimizing efficient SRM acquisition
- Visual display of relationship between chromatographic peak width and data points per peak to determine optimum quantitative performance
- FAIMS Compensation Voltage (CV) optimization routine performed on a chromatographic time scale
- Integration with multiple vendors' LC systems and autosampler configurations through Xcalibur software

### Scan functions

- Highly sensitive full-scan MS
  - Selected-ion monitoring (SIM)
  - SRM with up to 30,000 SRMs definable and up to 600 SRMs/sec and timed SRMs
  - High-resolution (0.2 Da FWHM) selected-reaction monitoring (H-SRM)
  - Product ion scan
  - Precursor ion scan
  - Neutral-loss scan
  - Reverse energy ramp MS/MS spectra (RER) gives information-rich MS/MS spectra for compound identification
  - Polarity switching capabilities
  - Quantitation-enhanced data-dependent (QED) MS/MS
  - Mixed Mode Scan Function
  - Automated on-the-fly adjustment of retention time windows to accommodate chromatographic fluctuations
- ### Optional application-specific software
- Thermo Scientific™ Chromeleon™ Chromatography Data System (CDS) software unifies workflows for routine quantitative MS analysis

- Thermo Scientific™ TraceFinder™ software simplifies method development and routine analysis in food safety, environmental, clinical research, and forensic toxicology laboratories
- Supports the use of Skyline software (MacCoss Lab, University of Washington)
- mzCloud database integration allows access to over 19,000 compounds

## Performance specifications

### Sensitivity\*

#### Positive electrospray (HESI)

A 5 µL injection of a 200 fg/µL reserpine solution will produce a minimum signal-to-noise ratio of 1,500,000:1 for the transition of the protonated molecule at  $m/z$  609.3 to the fragment ion at  $m/z$  195.1 when operated in SRM mode with Q1 and Q3 resolution set to 0.2 and 0.7 Da FWHM respectively.

#### Atmospheric pressure chemical ionization (APCI)

A 5 µL loop injection of a 200 fg/µL reserpine solution will produce a minimum signal-to-noise ratio of 100,000:1 for the transition of the protonated molecular ion at  $m/z$  609.3 to the fragment ion at  $m/z$  195.1 when operated in SRM mode with Q1 and Q3 resolution both set to 0.7 Da FWHM.

#### Negative electrospray (nHESI)

A 5 µL loop injection of a 200 fg/µL chloramphenicol solution will produce a minimum signal-to-noise ratio of 1,500,000:1 for the transition of the deprotonated molecular ion at  $m/z$  321.0 to the fragment ion at  $m/z$  152.0 when operated in SRM mode with Q1 and Q3 resolution set to 0.7 Da FWHM.

### Mass range

$m/z$  2–2010

### Resolution

Q1 and Q3 adjustable to 0.2 Da peak width (FWHM) across the entire mass range

### Scan rate

- 15,000 amu/second at a resolution of 2 Da FWHM
- Up to 600 SRMs/sec (for resolutions from 0.2 through 2.0 FWHM)
- Polarity Switching: 5 msec electronic switching time that includes signal stabilization

### Mass stability

Mass assignment will be within  $\pm 0.1$  Da over a 24-hour period. The laboratory room temperature must be maintained between 18–27 °C (65–81 °F). The room temperature may not change by more than 5 °C (9 °F) during this period.

## Installation requirements

### Power

- Three 230 Vac  $\pm 10\%$ , 50/60 Hz at 16 A minimum
- Four 120 Vac  $\pm 6$ – $10\%$ , 50/60 Hz at 20 A or four 230 Vac  $\pm 10\%$ , 50/60 Hz at 13 A

### Gas

- Collision gas: 99.995% pure Argon (99.995% Nitrogen also supported)
- Collision gas supply pressure: 135  $\pm$  70 kPa (20  $\pm$  10 psig)
- Sheath/aux/sweep gas: 99% pure Nitrogen
- Sheath/aux/sweep gas supply pressure: 690  $\pm$  140 kPa (100  $\pm$  20 psig)
- Maximum gas consumption: ~20 L/min
- Maximum gas consumption with the FAIMS Pro Duo interface installed: ~55 L/min

### Environment

- Functional temperature range: 15–27 °C (59–81 °F)
- Optimal temperature range: 18–21 °C (65–70 °F)
- MS Power consumption in scan mode (Heat output): 1,100 W (3,740 Btu/h)
- Total system power consumption (Heat output) with oil pump: 4,100 W (13,940 Btu/h)
- Total system power consumption (Heat output) with dry pump: 1,690 W (5,746 Btu/h)
- Total audible noise for TSQ Altis Plus MS with oil pump: 60 dB
- Total audible noise for TSQ Altis Plus MS with dry pump: 55 dB
- Particulate matter: <3,500,000 particles per cubic meter of air (<100,000 particles of >5 µm diameter per cubic foot of air)
- Relative humidity: 20% to 80%, without condensation
- Floors must be free of vibration

\*The signal-to-noise ratio is a manufacturing specification only. The signal-to-noise ratio specifies the minimum system response expected in accordance to the performance test for Reserpine and Chloramphenicol evaluated under the Thermo Fisher Scientific guidelines. The specified signal-to-noise ratio in the product specification sheet does not represent the limit of detection or limit of quantitation of the mass spectrometer or any assay. TSQ Altis Plus system is tested and installed according to the TSQ Altis Plus Installation Work Instructions using the Small Molecule Standard Solution. With the new installation procedure, we will officially withdraw from running the Signal-to-Noise sensitivity specs during the system installation.

## Dimensions

### Size

- TSQ Altis Plus MS: 680 × 760 × 840 mm  
(h, w, d – 27 × 30 × 33 in)
- 2 Oerlikon® SV 65 forepumps: 270 × 320 × 489 mm  
(h, w, d – 10 × 13 × 19 in)
- Edwards™ nXR120i dry forepump: 301 × 217 × 494 mm  
(h, w, d – 11.8 × 8.5 × 19.4)

### Weight

- TSQ Altis Plus MS: 125 kg (275 lb)
- 2 Oerlikon® SV 65 forepumps: 104 kg (230 lb)
- Edwards™ nXR120i dry forepump: 29 kg (64 lbs)

 Learn more at [thermofisher.com/AltisPlus](https://thermofisher.com/AltisPlus)

**General Laboratory Equipment – Not For Diagnostic Procedures.** © 2021-2023 Thermo Fisher Scientific Inc. All rights reserved. All trademarks are the property of Thermo Fisher Scientific and its subsidiaries unless otherwise specified. Intel is a registered trademark of Intel Corporation. Microsoft and Windows are registered trademarks of Microsoft Corporation. Oerlikon is a registered trademark of OC Oerlikon Corporation AG. Edwards is a trademark of Edwards Limited. This information is presented as an example of the capabilities of Thermo Fisher Scientific products. It is not intended to encourage use of these products in any manner that might infringe the intellectual property rights of others. Specifications, terms and pricing are subject to change. Not all products are available in all countries. Please consult your local sales representative for details. **PS66038-EN 1023M**